

Электродвигатели общепромышленные трёхфазные на лапах с малым фланцем В34

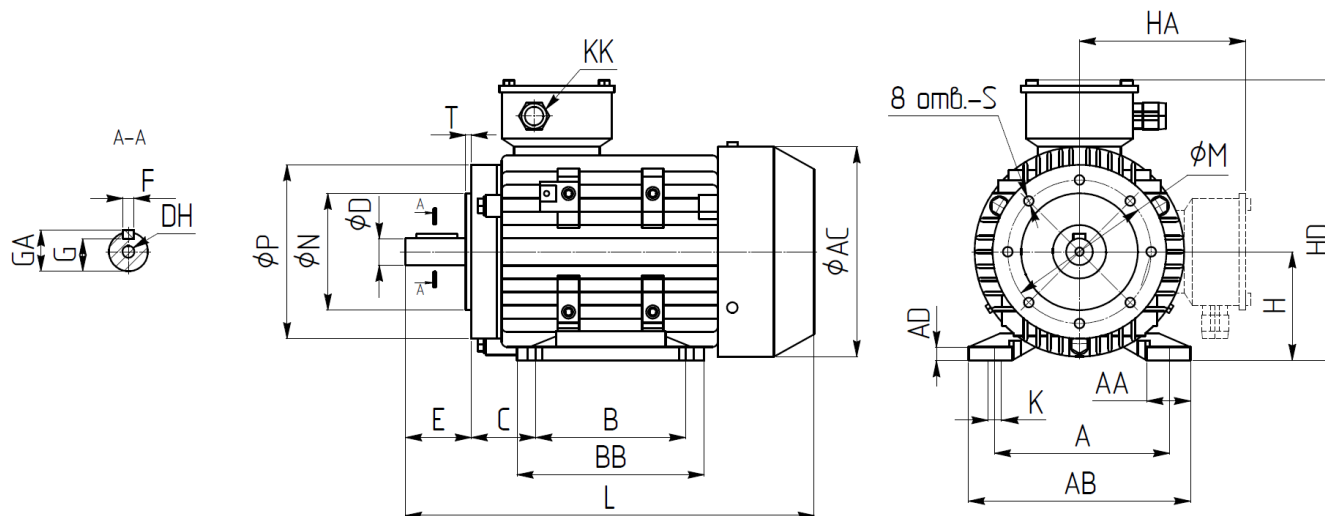

Размеры, мм

Тип	A	AA	AB	AC	AD	B	BB	C	D	DH	E	F	G	GA	H	HA	HD	K	KK	L	M	N	P	S	T
RM56	90	23	115	110	7	71	88	36	9	M4x12	20	3	7,2	10,2	56	100	156	5,8	M20x1.5	199	65	50	80	M5	2,5
RM63	100	24	137	123	7	80	100	40	11	M4x12	23	4	8,5	12,5	63	109	172	7	M20x1.5	221	75	60	90	M5	2,5
RM71	112	26	133	137	8	90	110	45	14	M5x12	30	5	11	16	71	127	198	7	M20x1.5	247	85	70	105	M6	2,5
RM80	125	35	157	155	9	100	125	50	19	M6x16	40	6	15,5	21,5	80	136	216	10	M20x1.5	290	100	80	120	M6	3
RM90S	140	37	175	175	10	100	125	56	24	M8x19	50	8	20	27	90	144	234	10	M25x1.5	315	115	95	140	M8	3
RM90/90L	140	37	175	175	10	125	150	56	24	M8x19	50	8	20	27	90	144	234	10	M25x1.5	340	115	95	140	M8	3
RM100L	160	40	200	195	11	140	172	63	28	M10x22	60	8	24	30	100	160	260	12	M25x1.5	382	130	110	160	M8	3,5
RM112M	190	41	226	220	12	140	181	70	28	M10x22	60	8	24	32	112	183	295	12	M32x1.5	400	130	110	160	M8	3,5
RM132S	216	51	260	258	14.5	140	186	89	38	M12x28	80	10	33	43	132	198	330	12	M32x1.5	469	165	130	200	M10	3,5
RM132M	216	51	260	258	14.5	178	223	89	38	M12x28	80	10	33	43	132	198	330	12	M32x1.5	508	165	130	200	M10	3,5
RM160M	254	60	314	315	18	210	260	108	42	M16x36	110	12	37	45	160	255	415	15	M40x1.5	613	215	180	250	M12	4
RM160L	254	60	314	315	18	254	304	108	42	M16x36	110	12	37	45	160	255	415	15	M40x1.5	658	215	180	250	M12	4